

Portemanteau Coat stand

Fernand

Design by **Adrian Blanc**

LES PLUS HIGHLIGHTS

- Pied lesté
- Fabrication : Portugal
- *Weighted base*
- *Made in Portugal*



INFORMATIONS SPÉCIFIQUES SPECIFIC DETAILS

Poids maximum par anneau : 2 Kg
Maximum weight per ring: 2 kg

DIMENSIONS ET POIDS DIMENSIONS AND WEIGHT

	Largeur Width Cm	Profondeur Depth Cm	Hauteur High Cm	Poids Weight Kg
Produit <i>Product</i>	28,5	28,5	180	6
Colis <i>Package</i>	27	27	190	8

MONTAGE ASSEMBLY

Base à assembler.
Livré avec visserie et notice.

*Base to be assembled.
Comes with screws and instructions*

USAGE USE

Conçu pour un usage en intérieur,
dans un espace non humide.

*Designed for indoor use, in a
non-humid space.*

CONSEILS D'ENTRETIEN CARE INSTRUCTIONS

Au quotidien : nettoyer avec un chiffon doux légèrement humide.

*On a daily basis: clean with a soft,
slightly damp cloth.*

Une question ? Contactez-nous grâce
au formulaire dédié sur notre site !
Have a question? Please contact us using
the dedicated form on our website!

 www.hartodesign.com



FR
Donnez ou recyclez
vos meubles.



Association



Magasin



Déchèterie

<https://quefairedemesdechets.fr>

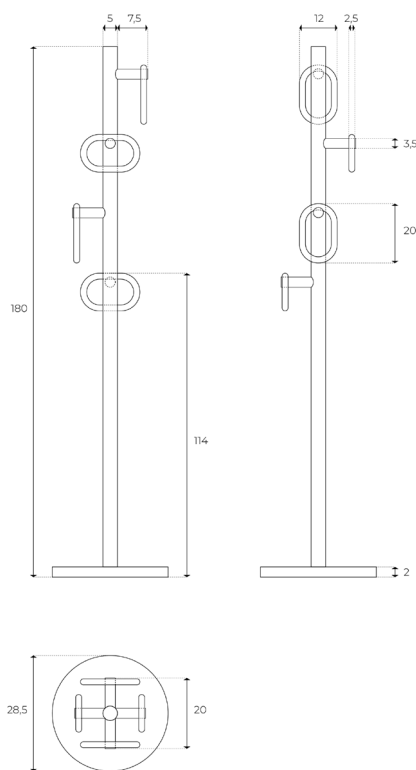

COULEURS COLOURS



Chêne
Bleu électrique -
NCS S 2565 R80B
*Oak
Electric blue -
NCS S 2565 R80B*

Ref. 12010723352



Chêne
Noir - RAL 9004
*Oak
Black - RAL 9004*

Ref. 12010723374

MATÉRIAUX MATERIALS

Bois massif
Multiplis laqué
*Solid wood
Lacquered plywood*

FINITIONS FINISHES

Bois vernis acrylique mat
Matt acrylic varnished wood